

# EGCP-3 LS

## Multi-unit Load Share Generator System Control Package

### DESCRIPTION

The EGCP-3 LS is a powerful microprocessor-based generator system control and management package designed for the most demanding power generation applications.

The EGCP-3 LS combines engine, generator, power system, switchgear, bus and generator monitoring, protection, and control functions in a single, compact, and cost-effective package.

Perfect for medium and large-sized generation systems, the EGCP-3 LS is designed for use in stand-alone, peaking, or utility paralleled systems.

The LS can be operated alone or networked together with other LS units or EGCP-3 MC units to provide a total system solution for most applications.



### APPLICATIONS

#### Real kW Load Control

- True RMS power calculations
- Speed bias signal to engine speed control, configurable for  $\pm 3$  Vdc, 0–5 Vdc, 500 Hz PWM, 4–20 mA, digital raise/lower
- Configurable load/unload ramp rates
- Isochronous load-sharing of up to 16 EGCP-3 LS units using percentage based load sharing
- Process control
- Externally adjustable load or process references (using Analog Inputs or Modbus)

#### Reactive kVAR Control

- Voltage bias signal to AVR configurable for digital raise/lower, 4–20 mA,  $\pm 1$ ,  $\pm 3$ , or  $\pm 9$  Vdc
- Configurable load/unload ramp rates
- PF sharing on isolated buses using percentage based reactive load sharing
- VAR/PF control using percentage based load sharing during process or baseload

- Externally adjustable VAR or PF references (using Analog Inputs or Modbus)
- Manual voltage control capability

#### Engine Control/Protection

- Configurable start sequencing
- KVA-controlled cooldown timer
- Oil pressure monitoring (idle/rated)
- Coolant temperature monitoring
- Battery voltage monitoring
- Speed monitoring with overspeed protection

#### Automatic Unit Sequencing

- Automatically starts and stops gen-sets based on plant load
- Automatic generator set loading and unloading for bumpless transfer
- Configurable plant load start/stop levels and timers
- Configurable generator priority sequencing

- Complete generator system control package
- Automatic load-demand sequencing of multiple units
- Synchronization of breakers or contactors
- Comprehensive system protection—engine, bus, and generator
- Revenue-grade power and energy metering
- Digital display of engine, bus, generator, and system data
- Real kW and reactive kVAR load sharing and control
- Advanced network communications with Echelon<sup>®</sup> and Modbus<sup>®</sup> networks
- DSLC<sup>™</sup> compatible (not compatible with manually bound DSLC units)
- Built-in system diagnostics

## Synchronizing

- Phase match or slip frequency synchronization with voltage matching
- Full three-phase sensing on both buses
- Manual synchronization capability
- Adjustable phase window, voltage window, re-close attempts, re-close timing
- Dead bus closing logic internal to the control
- Synch check (25)
- Breakers or contactors

## Communications

- Modbus® \* RTU via RS-232/-422/-485 serial ports
- ServLink, Watch Window via RS-232/-422/-485 serial ports
- Echelon® \*\* TP/XF-1250 network (LON)

## Diagnostic Features

- Breaker/Contactor synchronization timeout and re-close alarms
- Breaker/Contactor feedback and shunt trip alarms
- Phase rotation mismatch
- Network communication error alarms
- Speed/Frequency mismatch (loss of MPU)
- Analog input out-of-range alarms
- Configuration check

\*—Modbus® is a trademark of Modicon, Inc.

\*\*—Echelon® is a trademark of Echelon Corporation

## Bus Protective Features

- Over/Under Voltage (59, 27)
- Over/Under Frequency (81O, 81U)
- Directional (Forward/Reverse) Power (32) \*
- Negative Sequence Phase Overcurrent (46)
- Negative Sequence Phase Overvoltage (47)
- Phase Overcurrent (51) \*
- Voltage Restrained Phase Overcurrent (51V) \*
- Directional VAR
- Phase Current Imbalance (46) \*

## Generator Protective Features

- Over/Under Voltage (59, 27)
- Over/Under Frequency (81O, 81U)
- Directional (Import/Export) Power (32) \*
- Negative Sequence Phase Overcurrent (46)
- Negative Sequence Phase Overvoltage (47)
- Phase Overcurrent (51) \*
- Directional VAR
- Phase Current Imbalance (46) \*
- Speed/Frequency Mismatch
- Overspeed (12)

\*—Inverse Time Protections implemented are according to IEEE C37.112 "Very Inverse" curves

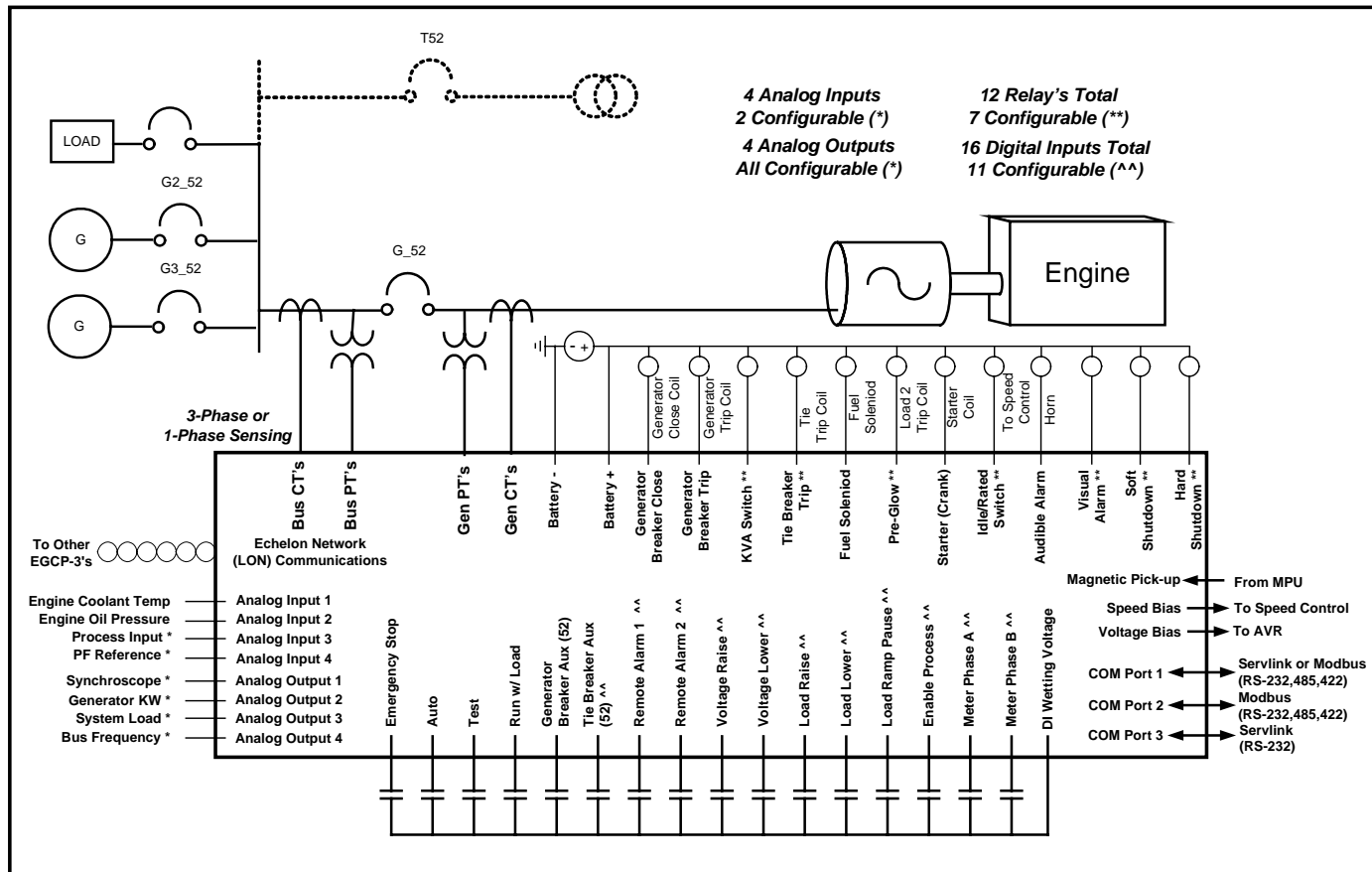

EGCP-3 LS Interactions

# HARDWARE SPECIFICATIONS

Size:	282 mm (11.1") high x 358 mm (14.1") wide x 134 mm (5.275") deep
Operator Interface Panel:	8 (20 character) lines plus membrane keypad
Power Supply Voltage:	24 Vdc system (18–32 Vdc nominal; 9–40 Vdc maximum)
Control Part Numbers:	LS: 8406-113 Installation Manual: 26122 Operation Manual: 26194
Connectors:	Terminal blocks are screwless CageClamp-style blocks. PT and CT inputs are fixed screw terminals.
Voltage Measuring Input Range:	70–300 Vac
Current Measuring Inputs:	5 Aac RMS nominal, 7 Aac RMS maximum
Temperature Range:	–20 to +70 °C (–4 to +158 °F) operating –30 to +80 °C (–22 to +176 °F) storage
Humidity:	95% at 60 °C non-condensing
Enclosure Rating:	Type 4 (NEMA) requirements from the front panel and properly installed in an equivalent enclosure
Vibration:	Suitable for engine skid or control cabinet Random Test: 10–2000 Hz at 0.04 G <sup>2</sup> /Hz and 8.2 Grms PSD
Mechanical Shock:	30 G peak, 11 ms duration, non-operating
Regulatory Compliance:	Class I, Division 2, Groups A, B, C, D for North America Zone 2, Group IIC for Europe Declared to the EMC; Low-Voltage, and ATEX Directives Type Approval by ABS, DNV, and LR for marine applications

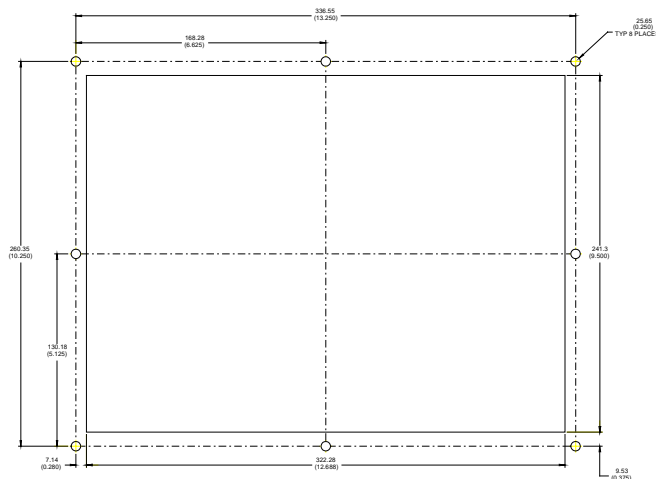
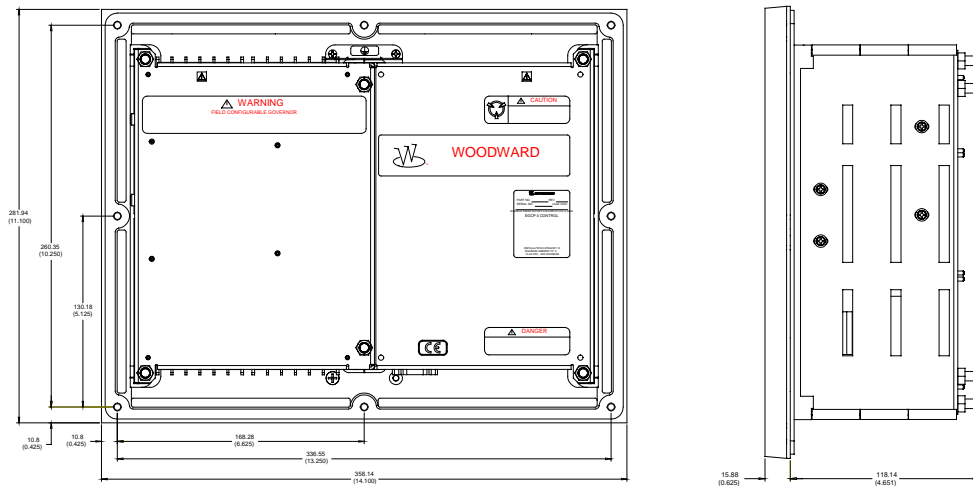

**EGCP-3 Outline Drawing and Panel Layout Template**  
(Do not use for construction)

PO Box 1519  
 Fort Collins CO, USA  
 80522-1519  
 1000 East Drake Road  
 Fort Collins CO 80525  
 Ph: +1 (970) 482-5811  
 Fax: +1 (970) 498-3058

**Distributors & Service**  
 Woodward has an international network of distributors and service facilities. For your nearest representative, call the Fort Collins plant or see the Worldwide Directory on our website.

**Corporate Headquarters**  
 Rockford IL, USA  
 Ph: +1 (815) 877-7441

[www.woodward.com](http://www.woodward.com)

## EGCP-3 LS Applications/Configurations

### Single Unit–No Parallel

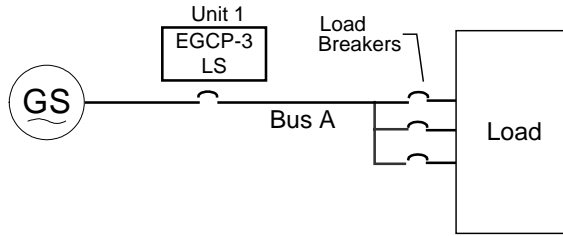

### Multiple Unit–No Parallel

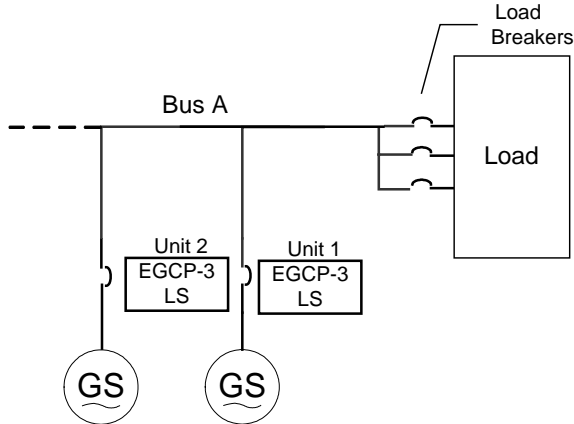

### Multiple Unit–Utility Parallel

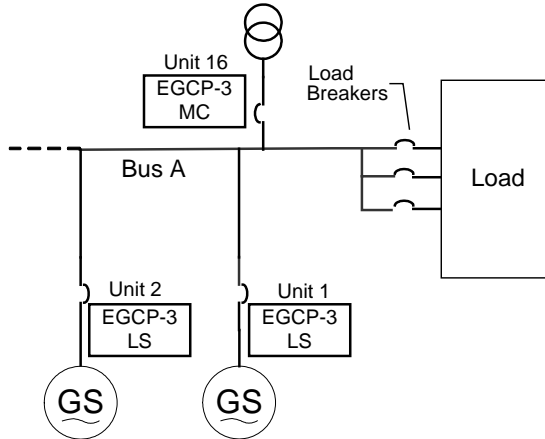

### Other Configurations

- Single Utility–Multiple Bus
- Multiple Utility–Single/Multiple Bus

For a complete set of EGCP-3 Installation/Operation manuals or Application Notes on the above configurations, download from the Woodward Industrial Controls website at:

[www.woodward.com/ic](http://www.woodward.com/ic)

This document is distributed for informational purposes only. It is not to be construed as creating or becoming part of any Woodward Governor Company contractual or warranty obligation unless expressly stated in a written sales contract.

© Woodward 2002  
 All Rights Reserved

06/3/F

For more information contact: